

# **Infological Model of e-Government**

**Sergei SHAVROV, Belarus Republic**

**Key words:** e-Government, e-land administration, cadastre, one stop shop

## **SUMMARY**

In this paper infological model of the E-government is offered. Infological model is a matrix. Elements of the matrix are function of an administrative procedure and its indexes. Sixteen indexes for each administrative procedure are offered. Indexes are identifying structure of each administrative procedure performance. The model is based on experience of the author in creation of e-land administration in Belarus E-government.

## **АННОТАЦИЯ**

Предлагается инфологическая модель Е-правительства. Инфологическая модель представляет матрицу, элементами которой является функция административной процедуры и ее индексы. Из опыта предлагаются шестнадцать индексов для каждой административной процедуры. Индексы идентифицируют структуру исполнения каждой административной процедуры. Модель основана на опыте автора в создании е-земельного администрирования в составе Е-правительства Республики Беларусь.

# Infological Model of e-Government

Sergei SHAVROV, Belarus Republic

Many definitions of the term "E-government" are known. For example, in documents of World Bank the electronic government is understood as use of information and communication technologies for increase of efficiency, profitability and a transparency of the government and an opportunity of public control above it [1].

All these definitions likely to be correct, but all of them have too general character. The author suggests defining E-government through infological model. Infological models are more or less simply identify complex subjects of consideration.

Let's consider the figure 1. It illustrates structure of the E-government and information streams in the E-government.

Information basic resources **BR** are key elements of the E-government. They declared by State as a basic one and should meet to certain requirements. These resources provide delivery of governmental information for rendering services to state organizations, citizens and business.

One more important element of the E-government is "gateways" through which the government carries out of information deliveries and renders e-services. Allocate two kinds of such "gateways": portals **P** and *front-offices* **FO**. *Front-offices* are state organizations through which applications enter into the E-government. *Front-offices* produce administrative services (procedures) in reply to these applications. Applicants are citizens **C** or legal persons **B**. Portals play a role of "self-acting" *front-offices*.

Besides of *front-offices* the structure of the E-government includes so-called *back-offices* **BO**. *Back-offices* **BO** render services to *front-offices* **FO**. *Back-offices* possess basic state information resources **BR**. State organization can simultaneously act as *front-office* for one service and as a *back-office* — for other.

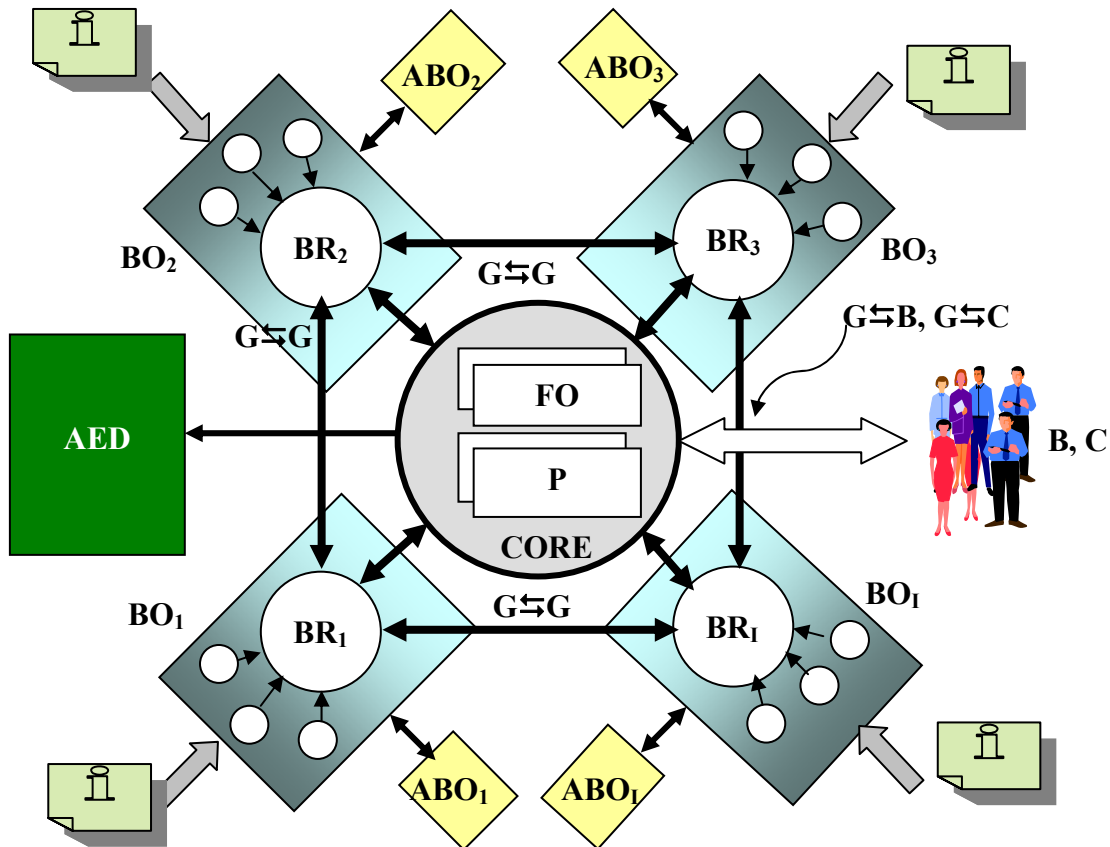

**Figure 1.** E-government block diagram and E-government information streams.

*Back- and front-offices* together realize «one stop shop» technologies. Usually a technology of administrative procedures in the stop shop regime is characterized by the following attributes:

- -applicant and application for administrative procedure execution;
- -*front-office* (portal) which accepts search about execution of an administrative procedure, creates a stream of events of its performance by other organizations and delivery of result to the applicant;
- -set of *back-offices* which carry out actions directed to execution of an administrative procedure under the control of *front-office* or specialized structure **CORE**;
- -scenario for *front-office/back-offices*, *back-offices/back-offices* team-work in administrative procedure execution.

Digital archives are components of the E-government. It is reasonable to divide digital archives on two categories. The first category are digital archives of initial documents **ABO1**, ..., **ABOI**. Initial documents are documents on which basic information resources **BR** have been formed. The second category is digital archives of electronic document **AED** that are in exchange. Unfortunately, a role of digital archives as a component of the E-governments is underestimated.

Three kinds of information streams are distinguishing in E-government: "state - state"  $G \leftrightarrow G$ , «state - citizens»  $G \leftrightarrow C$  and «state - legal persons»  $G \leftrightarrow B$ . Each of these streams has the especial legal foundation.

The author of this paper has wide experience in development and use of e-land administration in E-government according figure 1 in Belarus. In many cases it is convenient to describe E-government not as a structure look like figure 1, but as a matrix  $M_{E-GOV}$  (1). The author named this matrix “infological model of the E-government”. Let’s consider it in details.

$$M_{E-GOV} := \begin{pmatrix} F_1 & J_{1,1} & J_{1,2} & J_{1,3} & J_{1,4} & J_{1,5} & \dots & J_{1,K} \\ F_2 & J_{2,1} & J_{2,2} & J_{2,3} & J_{2,4} & J_{2,5} & \dots & J_{2,K} \\ F_3 & J_{3,1} & J_{3,2} & J_{3,3} & J_{3,4} & J_{3,5} & \dots & J_{3,K} \\ \dots & & & & & & & \\ F_N & J_{N,1} & J_{N,2} & J_{N,3} & J_{N,4} & J_{N,5} & \dots & J_{N,K} \end{pmatrix} \quad (1)$$

Elements of the matrix are functions  $F_i$  and indexes  $J_{ik}$ .

Functions  $\{F_i\}$  are administrative procedures nominated by the State. They should be recognized and specified by legislation. In Belarus they have specified by President Decrees or by Governmental orders.

Administrative procedure  $F_i$  is identified by two basic attributes: title and legislation due to it appears.

Structural properties of each function  $F_i$  in (1) are described by indexes  $J_{ik}$  of a matrix. The author in his work most frequently uses 16 indexes.

**J1: Class of administrative procedure.** The World Bank in [1] administrative processes in the E-government subdivides into three types: type *G2G* (*Government to Government*), type *G2B* (*Government to Business*), *G2C* (*Government to Citizens*). Each of the specified types has the specificity. For example, administrative process *G2G* usually is based on agreements between state organizations. Process *G2B* is based on civil contracts. Process *G2C* is based on normative legal documents. Specificity is expressed also in principles of payment, access methods and so on.

**J2: Speed of administrative processes in the E-government.** The given index accepts value: *on-line* or *off-line*.

**J3: Information resources of the E-government.** Not every information resource can be declared as a E-government resource **BR**. First, it is obliged to have the certain level of integrity. Second, there should be a normative-legal basis for information resource conducting. The legislation should designate the mechanism of gathering of the information (inspection, registration, declaring) and the mechanism of indemnification of damages caused by loss of integ-

riety. Thirdly, the resource should be claimed by administrative procedures. Fourthly, information systems for **BR** conducting should possess certain reliability and survivability.

The analysis shows that composition of basic information resources in different countries is approximately identical. Usually 4-6 following state databases are declared as a basic resources: «physical persons (register of citizens)», «legal persons (trading register)», «cadastre and Land Register», «address register» and the registry keeping data on the administrative-territorial units of the country. Basic registers are defined by governments as authentic registers with high quality of data. For such registers clear guarantees of their quality have to be given, including guarantees of integrity.

**J4: Integrity of E-government information resources.** The information distributed by the state should be authentic. Consequences unreliable information distribution is obvious. Government adopts erroneous decisions. As a result, consequences have not only economic, but also political, social, law-enforcement character. Banks distribute unreasonable credits. Citizens accomplish illegal transactions. Tax administration suffers from failures. In Belarus safety of cadastre and land registry system depends of its data integrity. According registration law registration organization is obliged to compensate full losses if issued data contain inadequate information.

Integrity is a parameter which characterizes databases quality. A level of integrity is reflecting reliability, completeness and consistency of data base. In Belarus the level of integrity of a cadastre and the land register is normalized by number from 0 up to 1. This level is supervised by special rules monthly. To reach high integrity the personal parameter of integrity is given even to Registrars (there are approximately 800 Registrars in Belarus). Integrity may take on a value of 5 levels: excellent (a low class of risk data using), high (a usual class of risk), average (a satisfactory class of risk), bad (a high class of risk), catastrophic (an unacceptable - high class of risk).

Integrity of the E-government is determined by integrity of the most unreliable **BR**. State should have a system to monitor the **BR** integrity. **BR** integrity level is the object for standardization. This index should be considered as an element of the E-government security.

**J5: Legal status of E-government information.** It is rationally to distinguish between two legal statuses of the information: the electronic document and a simple information report. The electronic document has an evidential effect because his authenticity is provided with special attribute. This attribute is a digital signature. A simple information report is a digital object, received from a database without the digital signature.

**J6: Name of a *front-office* FO or a portal.**

**J7: Names of *back-offices* BO participating in services to front-office for administrative procedure  $F_i$ .**

**J8: Architecture of information system.** The administrative procedure  $F_i$  is realized by the certain IT-architecture. E-government architecture can accept various forms and their combinations. Each administrative procedure has specific architecture. The modern approach is SOA with its standards (XML, SOAP, WSDL, ...). SOA can coexist with separate information systems with their own architecture: client - server, architecture for distributed databases, architecture of corporate networks, Internet - applications and etc.

**J9: E-government communications.** E-government channels strategy greatly defines not only the quality of delivering services, but also their cost. The index can accept following values or their combinations: switched channel, allocated channels, Internet channel, VPN-channel, email etc.

**J10: Front-office software.** This index can accept values: DB control system, special applied software, a browser, etc.

**J11: Access to data.** Safety data distribution is adjusted by strategy of rules and technologies of access to the information. The index specifies, whether access to the information is anonymous or authorized, onerous or gratuitous, motivated or unmotivated.

**J12: Intervals of services.** E-government has the opportunity to work «without the rest»: 24 hours per day, 365 days in one year. The given index can also accept other values.

**J13: Payment for E-government services.** It is possible to allocate some versions of this index: payment on the contractual basis, payment by cash or by cards through banks, real time electronic payments. There are different payment cases between *front-* and *back-* offices.

**J14: E-government digital archives.** This index consists of such entities as data producers, data consumers, archive management, content information, Preservation Description Information, metadata. There are different standard for Open Archival Information System. Some of them are as follows: standards for interfaces between OAIS type archives; standards for the submission of digital data sources to the archive; for the delivery of digital sources from the archive; for the submission of digital metadata; about digital or physical data sources to the archive; standards to search and retrieve metadata information about digital and physical data sources; standards for the migration of information across media and formats and so on.

**J15: Public data re-using rules.** Huge data streams are moving in E-government environment. Some of the data are confidential, for example, personal data. This and other factors make importance to have rules of re-using **BR** data. These rules should be clear from the legislation. These rules may be established by agreements due to which streams **G $\rightarrow$ G**, **G $\rightarrow$ B**, **G $\rightarrow$ C** have been created.

**J16: E-government survivability.** Survivability is a preservation of capacity for work in the time of equipment failure. Loss of capacity is equivalent to the damage of the state infrastructure. Citizens, legal persons in processes *G2C*, *G2B* do not receive corresponding state ser-

vices. State in processes *G2G* stops execution of its functions. One of parameters of survivability is the probability of refusal of information system or its part.

*E-land administration* occupy 18 lines in the Belarus E-government matrix (1) for such functions  $F_i$  as crediting, excavations administration in cities, notary and court activities, land parcel formation, lease payment establishment for state land parcels, land privatization, tax administration (several tax types), real property transactions via realtors, housing, state property auctions selling and other.

## REFERENCES

1. UN Global E-government Readiness Report 2005. From E-government to E-inclusion / Department of Economic and Social Affairs, Division for Public Administration and Development Management, UNPAN.2005, [www.unpan.org/egovernment2.asp](http://www.unpan.org/egovernment2.asp) .

## BIOGRAPHICAL NOTES

**Sergei Shavrov** is a director of National Cadastre Agency, Ph.D. Agency is subordinated to the Belarus State Committee for Property. He is one of the co-author of the National Registration Law. For a long period worked in the IT field for digital terrain computer applications. Ten last years is working in the sphere of Land Administration. He is the member of the Bureau of UNECE Working Party on Land Administration (2007).

## CONTACTS

Sergei Shavrov  
National Cadastre Agency  
P.O. Box 127  
Minsk-88  
BELARUS REPUBLIC  
Tel. +375-17-285 39 26  
Email: [shavrov@nca.by](mailto:shavrov@nca.by)  
Web site: [www.nca.by](http://www.nca.by)